

Art. 160.1200

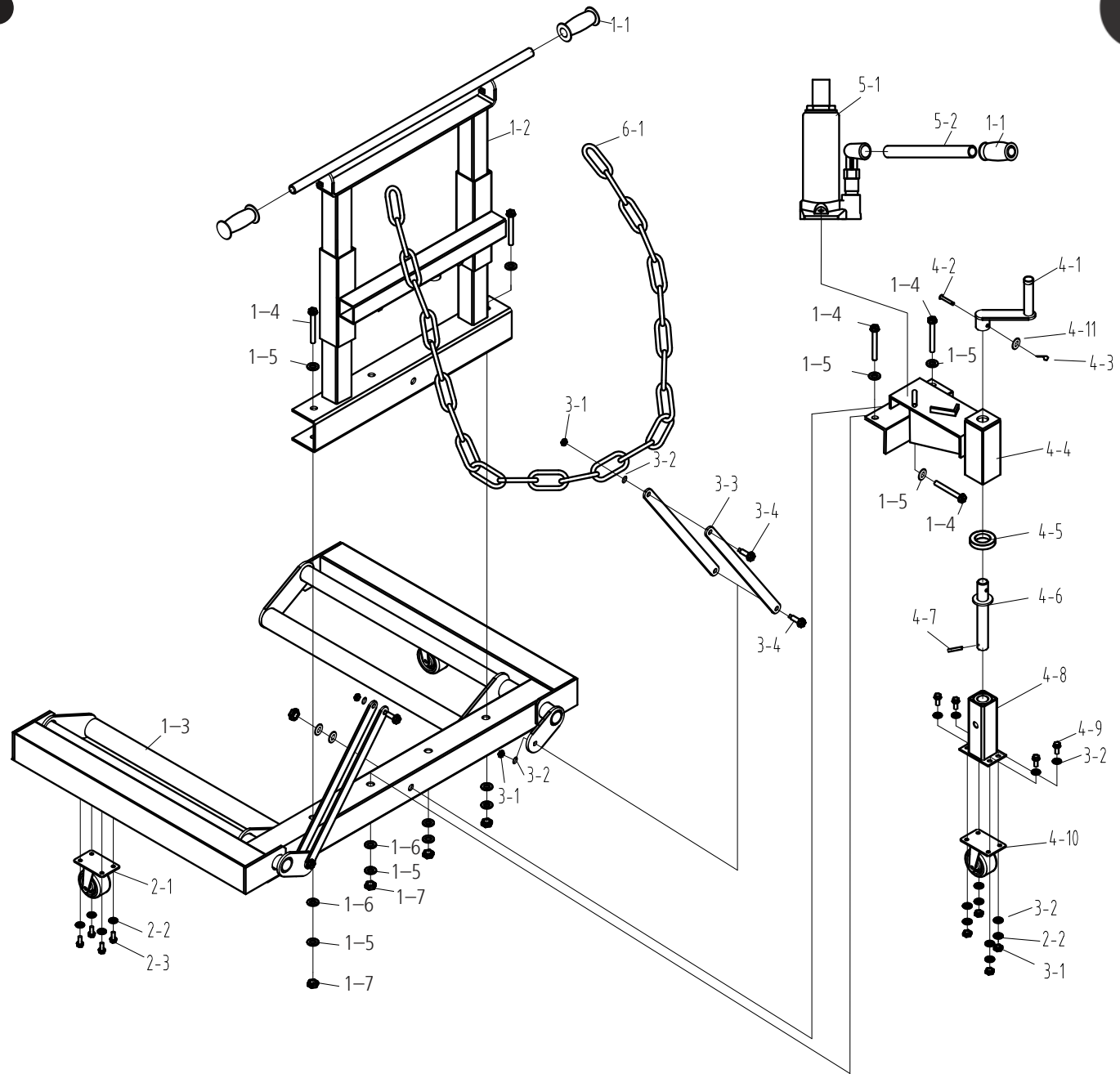

**Art. 160.1200**

Part. No	Art.-Nr.	Beschreibung	Description	Menge Qty.
1-1	160.1200-R001P	Handgriff	Handle Sleeve	3
1-2	160.1200-R002P	Vertikaler Rahmen	Vertical Ass'Y	1
1-3	160.1200-R003P	Hochizontaler Rahmen	Horizontal Ass'Y	1
1-4	160.1200-R004P	Schraube M12x110	Bolt M12x110	5
1-5	160.1200-R005P	Unterlegscheibe	Flat Washer	10
1-6	160.1200-R006P	Unterlegscheibe	Lock Washel	5
1-7	160.1200-R007P	Mutter M12	M12 nut	5
2-1	160.1200-R008P	Vorderes Rad	Front Caster	2
2-2	160.1200-R009P	Unterlegscheibe	Washer	16
2-3	160.1200-R010P	Schraube M8x18	Screw M8x18	8
3-1	160.1200-R011P	Mutter	Nut	4
3-2	160.1200-R012P	Unterlegscheibe	Flat Washer	4
3-3	160.1200-R013P	Bolzen	Bolt	4
3-4	160.1200-R014P	Verbindungsstange	Connection Bar	4
4-1	160.1200-R015P	Drehgriff	Crank Handle	1

Part. No	Art.-Nr.	Beschreibung	Description	Menge Qty.
4-2	160.1200-R016P	Bolzen	Pin	1
4-3	160.1200-R017P	Bolzen	Pin	1
4-4	160.1200-R018P	Halter für Lenkrolle	Crank Ass'Y	1
4-5	160.1200-R019P	Kugellager	Bearing	1
4-6	160.1200-R020P	Spindel	Screw Rod	1
4-7	160.1200-R021P	Bolzen	Pin	1
4-8	160.1200-R022P	Teleskopopstange	Screw Rod Outer Tube	1
4-9	160.1200-R023P	Schraube	Screw	4
4-10	160.1200-R024P	Lenkrolle	Rear Caster	1
4-11	160.1200-R025P	Unterlegscheibe	Lock Washer	4
5-1	160.1200-R027P	Hydraulikeinheit	Jack	1
5-2	160.1200-R028P	Betätigungsstange für Hydraulikeinheit	Jack Handle	1
6-1	160.1200-R029P	Kette	Chain	1