

Art. 160.1285

KSTOOLS®

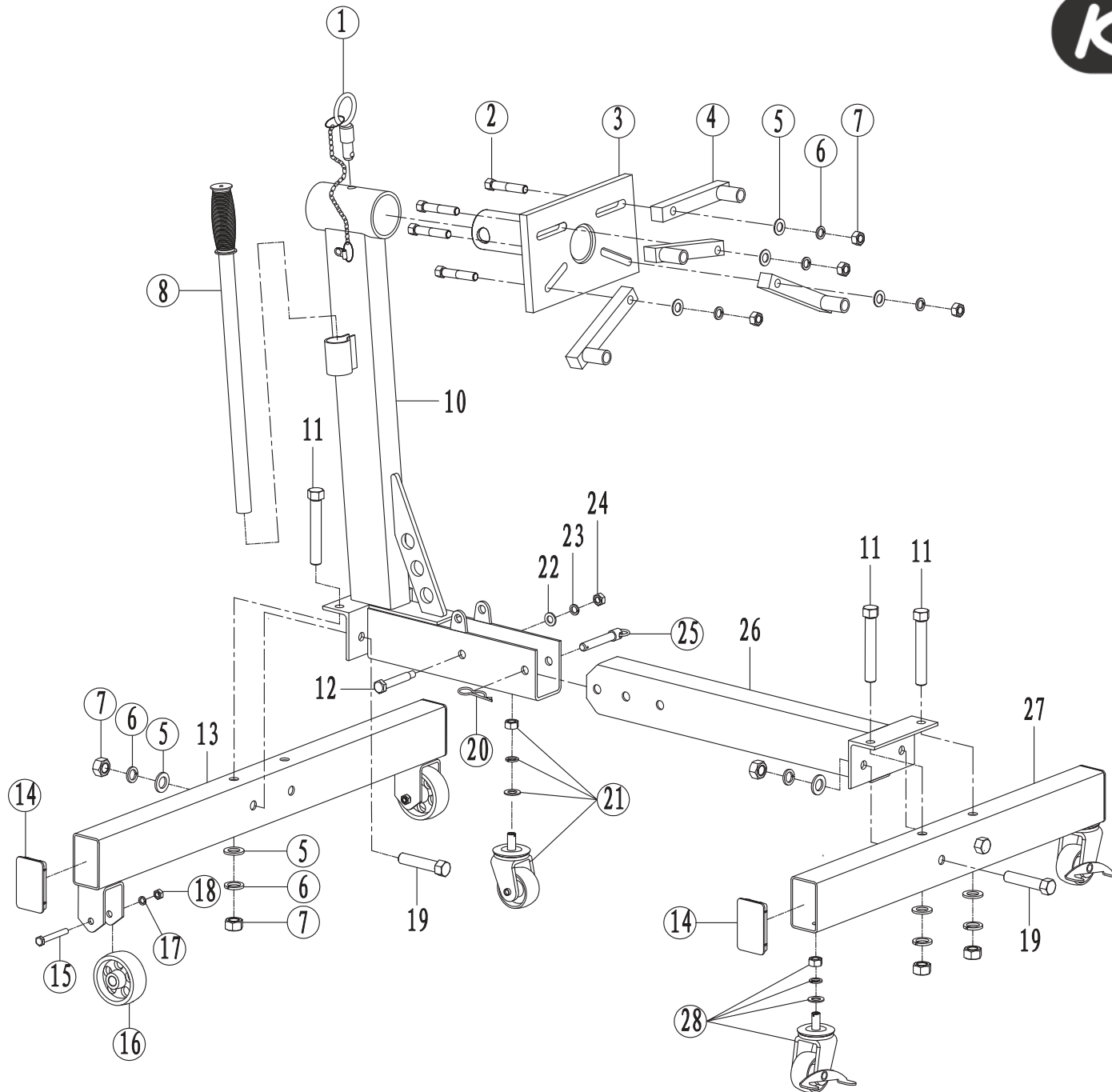

Art. 160.1285

Part. No	Art.-Nr.	Beschreibung	Description	Menge Qty.
1	160.1285-R001P	Sicherungsbolzen mit Kette	Lock pin assembly	1
2	160.1285-R002P	Schraube	Hex head bolt	4
3	160.1285-R003P	Aufnahmeplatte	Head assembly	1
4	160.1285-R004P	Aufnahmearme	Mounting arms	4
5	160.1285-R005P	Unterlegscheibe	Washer	15
6	160.1285-R006P	Federring	Spring washer	15
7	160.1285-R007P	Mutter	Nut	15
8	160.1285-R008P	Lenkstange	Handle assembly	1
10	160.1285-R010P	Haupttraverse	Main post	1
11	160.1285-R011P	Schraube	Hex head bolt	4
12	160.1285-R012P	Schraube	Hex head bolt	1
13	160.1285-R013P	Hintere Traverse	Rear support beam	1
14	160.1285-R014P	Plastikkappe	Plastic end cap	4
15	160.1285-R015P	Schraube	Hex head bolt	2

Part. No	Art.-Nr.	Beschreibung	Description	Menge Qty.
16	160.1285-R016P	Rad	Wheel	2
17	160.1285-R017P	Federring	Spring washer	2
18	160.1285-R018P	Mutter	Nut	2
19	160.1285-R019P	Schraube	Hex head bolt	4
20	160.1285-R020P	Sicherungssplint	Roundwire snap ring	1
21	160.1285-R021P	2,5" Lenkrolle	2.5" Caster wheel	1
22	160.1285-R022P	Unterlegscheibe	Washer	12
23	160.1285-R023P	Unterlegscheibe	Washer	1
24	160.1285-R024P	Mutter	Nut	1
25	160.1285-R025P	Bolzen	Bolt	1
26	160.1285-R026P	Verbindungstraverse	Wheel frame connection tube	1
27	160.1285-R027P	Vordere Traverse	Front wheel frame	1
28	160.1285-R028P	3" Lenkrolle mit Feststellbremse	3" Brake wheel	2